

# Assembly Instructions

(English Translation)

(in accordance with EC Machinery Directive 2006/42/EC,  
 Annex VI for Incomplete Machines)  
 and ATEX Directive 94/9/EC

for

## Axial Fans in explosion-hazardous areas

(Atmosphere Gas)

Model series MD - \_\_\_\_ - \_\_\_\_ -X (standard models)

Model series MD - \_\_\_\_ - \_\_\_\_ -W (with protection cover)

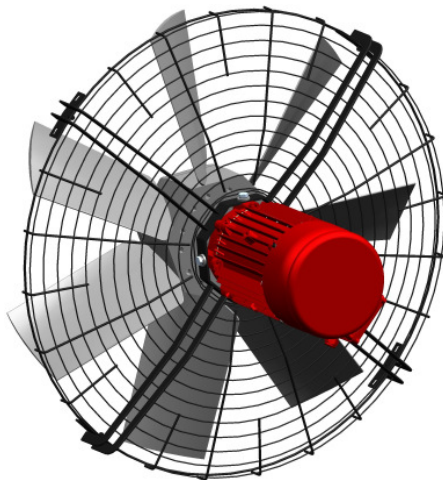

SÜD-ELECTRIC AG  
 Westring 1-7  
 D-85614 Kirchseeon  
 www.suedelectric.de

motors and fans  
**SÜD-ELECTRIC**   
 Member of the Ziehl-Abegg Group

Status: December 2010

Part No. 164549

### Contents

<b>1.</b>	<b>Important basic information</b> .....	<b>4</b>
1.1	Information pertaining to these assembly instructions .....	4
1.2	Legal information .....	4
1.2.1	Limitation / Exclusion of liability .....	4
1.2.2	Copyright .....	4
1.2.3	Warranty .....	4
1.3	Documentation .....	5
1.3.1	Explanation of safety symbols .....	5
1.3.2	Drawings .....	5
1.4	Manufacturer and service .....	6
<b>2.</b>	<b>Safety</b> .....	<b>7</b>
2.1	Use as intended .....	7
2.1.1	Application .....	7
2.1.2	Ambient safety conditions .....	8
2.2	Improper use .....	9
2.2.1	Possible application errors .....	9
2.2.2	Modifications / Changes to device .....	9
2.3	Product safety .....	9
2.4	Operator's responsibilities .....	10
2.4.1	General .....	10
2.4.2	Staff safety, requirements / Duty of care .....	10
2.4.3	Personal safety equipment .....	10
2.4.4	Work carried out by external persons .....	11
2.5	General dangers .....	11
2.6	Safety instructions for phases in the product lifecycle .....	12
2.6.1	Installation .....	12
2.6.2	Operation .....	12
2.6.3	Maintenance and service, disassembly and waste disposal .....	12
2.7	What to do in an emergency .....	12
<b>3.</b>	<b>Technical data</b> .....	<b>13</b>
<b>4.</b>	<b>Construction and function</b> .....	<b>14</b>
4.1	Main components .....	14
4.2	Functional description .....	14
<b>5.</b>	<b>Transport and storage</b> .....	<b>15</b>
5.1	Safety .....	15
5.2	Packaging and transport .....	15
5.3	Storage .....	15

<b>6.</b>	<b>Assembly and installation, initial operating .....</b>	<b>16</b>
<b>6.1</b>	<b>Safety .....</b>	<b>16</b>
<b>6.2</b>	<b>Assembly and installation .....</b>	<b>16</b>
6.2.1	General information .....	16
6.2.2	Mechanical installation .....	17
6.2.3	Explosion group IIC .....	18
6.2.4	Cable gland .....	19
6.2.5	Electrical Connection .....	19
<b>6.3</b>	<b>Initial operation.....</b>	<b>20</b>
<b>7.</b>	<b>Operation and maintenance.....</b>	<b>21</b>
<b>7.1</b>	<b>Safety .....</b>	<b>21</b>
<b>7.2</b>	<b>Operating conditions.....</b>	<b>21</b>
<b>7.3</b>	<b>Instructions for use of PTC thermistors .....</b>	<b>21</b>
<b>7.4</b>	<b>Outdoor installation .....</b>	<b>22</b>
<b>7.5</b>	<b>Maintenance and service .....</b>	<b>22</b>
<b>7.6</b>	<b>Cleaning .....</b>	<b>23</b>
<b>8.</b>	<b>Fault diagnostics .....</b>	<b>24</b>
<b>8.1</b>	<b>Safety .....</b>	<b>24</b>
<b>8.2</b>	<b>What to do in the case of failure and disruptions.....</b>	<b>24</b>
<b>8.3</b>	<b>Fault diagnostics and elimination.....</b>	<b>24</b>
<b>9.</b>	<b>Disassembly and waste disposal .....</b>	<b>26</b>
<b>9.1</b>	<b>Safety .....</b>	<b>26</b>
<b>9.2</b>	<b>Disassembly.....</b>	<b>26</b>
<b>9.3</b>	<b>Waste disposal / Recycling .....</b>	<b>26</b>
<b>10.</b>	<b>Declaration of incorporation.....</b>	<b>27</b>

<b>1.</b>	<b>Important basic information</b>
<b>1.1</b>	<b>Information pertaining to these assembly instructions</b>

**To ensure correct use, please read these assembly instructions carefully before installation and commissioning!  
 Please note that these assembly instructions apply to a designated device and on no account to a complete machine!**

These assembly instructions serve to ensure the safe operation of the designated machine. They are also relevant to any work carried out thereon. These instructions contain safety information which must be adhered to as well as information which ensures the failure-free operation of the machine. The assembly instructions must be kept with the machine. All persons who carry out work on the machine must have easy access to the assembly instructions at all times. The assembly instructions are to remain with the machine and must be passed on to any subsequent owner, user or end customer. The assembly instructions meant for all persons connected with the planning, installation, commissioning or service and maintenance and who are suitably qualified and experienced to carry out their work.

**1.2 Legal information**

1.2.1 Limitation / Exclusion of liability

The contents of these assembly instructions were checked against the design details of the devices but may vary nevertheless; Süd-Electric cannot guarantee that the documentation matches identically. In the interests of further development, we reserve the right to make modifications to the construction and technical data. No claims can be made therefore based on the information, drawings or descriptions. No liability is accepted for errors. Süd-Electric AG is not liable for damage caused by incorrect, inappropriate or improper use or as a result of unauthorised repair or modifications.

1.2.2 Copyright

These assembly instructions contain information protected by copyright law. It is therefore illegal to photocopy, copy, translate or store on data storage media all or part of these instructions without the prior consent of Süd-Electric AG. All violations are liable for damages. All rights reserved, including those arising from patents or registered design.

1.2.3 Warranty

Please refer to "Technical Explanations" Chap. 28 "Warranty".

### 1.3 Documentation

#### 1.3.1 Explanation of safety symbols



**ATTENTION! or WARNING!**

General danger spot. Death, risk of severe personal injury or considerable material damage can arise if appropriate safety measures are not taken!



**DANGER FROM ELECTRICAL CURRENT!**

Warning of dangerous voltage or current



**IMPORTANT INSTRUCTION**



**INFORMATION**

Important additional information and application tips

#### 1.3.2 Display

Especially important information is printed in bold type in boxes with a grey background.

### 1.4 Manufacturer and service

#### Manufacturer information

Our products are manufactured in accordance with current international standards. If you have questions regarding the application of our products or you are planning special applications, please contact:

**Süd-Electric AG**  
**Westring 1-7**  
**D-85614 Kirchseeon**

**Tel.: +49(0)8091/5657-0**  
**Fax: +49(0)8091/5657-58**

**info@suedelectric.de**  
**www.suedelectric.de**

#### Service information

If technical questions arise during commissioning or in the case of machine failure, please contact our Support Department (Technical Sales).

As part of the Ziehl-Abegg Group, we have service engineers in our subsidiaries around the world. ☞ **www.ziehl-abegg.com**

In the case of returns sent back for testing or repair, we need certain information in order to carry out efficient trouble shooting and to facilitate fast repair. Please refer to our annexed data sheet. After consultation, this will be sent to you by our Support Department.



Please refer also to our documentation “Technical Explanations” at  
 ☞ **www.suedelectric.de/download.htm**

## 2. Safety

This section provides you with an overview of all important safety aspects which ensure optimum protection for your staff and safe and trouble-free operation.

Non-compliance with the information and safety instructions contained in these assembly instructions can lead to serious danger.

### 2.1 Use as intended



- The fans are intended for the transfer of air or air-like mixtures only.
- With explosion proof fans, operation is permissible with gases, mist vapours and mixtures in explosive areas for Zone 1 and Zone 2. Gases, mist or mist vapours may only be mixed with air under normal pressure and with normal oxygen content.
- Any other use or use above and beyond the transfer of air or air-like mixtures is deemed unintended use unless contrary written agreements have been made. The manufacturer is not liable for any damage resulting from such unintended use. All risks are borne solely by the “user” company.
- Fans must not be used for the transfer of solid materials or solid components in the transfer medium.
- Normal usage includes the reading of this document as well as adherence to all instructions herein – especially safety instructions.
- Please observe all documentation pertaining to connected components.





#### WARNING!

**Danger from misuse! Any machine use above and beyond or variant to its intended use can lead to hazardous situations.**

#### 2.1.1 Area of application

Süd-Electric motors and fans for gas correspond to the following norms:

EN 13857:2008    EN 60034-1:2004    EN 60079-0:2004    EN 60079-7:2007  
EN 13463-1:2001    EN 13463-5:2003    EN 14986:2007 and the Directive 94/9/EC

Motor designation	 II 2 G Ex e II T....
Fan designation	 II 2 G Ex c IIB T.... Fan for application in explosion group IIA and IIB
	 II 2 G Ex c IIC T....X Fan for application in explosion group IIA, IIB and IIC (only hydrogen) see chapter 6.2.3

Explosion-proof motors can be applied as drives for axial fans in combination with fan impellers of Süd-Electric.

The fans are not ready-to-use products and may be operated only when they have been installed according to their intended use in ventilation technology devices and safety is ensured by means of safety devices in accordance with DIN EN ISO 13857 (DIN EN ISO 12100) or other safety measures.

☞ Please observe information in the chapters “Technical Data” and “Operation and Maintenance”.

The machine builder is responsible for sealing the housing!

#### 2.1.2 Ambient safety conditions

- The permissible ambient temperature is -20°C to + 40°C. For deviating ambient temperatures, please refer to the rating plate and the respective data sheet of the EC type examination certificate.
- Operate the fan within the ranges shown on the rating plate only. The max. permissible operating data also apply for an air density of  $\rho = 1,2 \text{ kg/m}^3$ .
- Performance data refer to the motor’s own cooling without fan impeller.
- In order to avoid disruptions and to protect the motor, an approved electrical monitoring device in accordance with Guideline 94/9/EC and according to EN 60079-14 must be used. This device must be set according to the rated current and its tripping characteristic<sup>1</sup> must lie **under** the turn-on current and  $t_E$  -time for the required temperature class. If the motor is operated corresponding to the rating plate data with a delta connection, a safety device built in to the mains power supply must have not only over-current but also phase failure protection and machine asymmetry recognition.
- The motors are designed for continuous operation with light and infrequent recurrent start-ups.
- Safe run-up (within the time  $t_E$ ) is generally guaranteed for all Süd-Electric fan-motor units.
- Only use motors as intended and only for the tasks shown on the order form! Compare requirements for the relevant application with the rating plate.
- For temperature class and, if necessary, tripping time  $t_A$ , please refer to the corresponding data sheet of the EC type examination certificate.
- If a risk of lightening is identified, the machine must be protected by appropriate lightning protection measures.
- Machines must be a safe distance from transmitters or protected by appropriate shielding.

<sup>1</sup> The tripping characteristic must be available at the place of operation!

## 2.2 Improper use

### 2.2.1 Possible application errors

- Operation with icy fan impeller
- The transfer of abrasive or sticky media
- The transfer of fluid media
- Use of fan including mounting parts (e.g. safety grille) as storage rack or as climbing aid
- Unauthorised modification to the construction of the fan
- Operation of fan as a safety component or for to take on a safety function according to DIN EN ISO 13849-1
- Blocking or slowing of fan by inserting object
- Removing fan wheel from motor
- All other applications not stipulated in the standard compliant usage section

**All liability for personal injury and material damage resulting from non-compliant use rests with the operator of the device alone and not with the manufacturer.**

### 2.2.2 Modifications / Changes to device



**WARNUNG!**

**For safety reasons no unauthorised modifications may be made to the device. Any planned modifications require written consent from the manufacturer.**

Use only Süd-Electric original spare parts / original wear parts / original accessories. These parts have been especially designed for the device. In the case of non-original parts, Süd-Electric cannot guarantee that the parts have been designed and manufactured to comply with wear and tear or safety standards. Süd-Electric does not authorize the use of parts delivered by other manufacturers.

## 2.3 Product safety

At the time of delivery the device corresponds to state-of-the-art technology and is generally considered safe to operate. The device and accessories may only be installed and operated if in perfect working condition; assembly instructions or operating instructions must be adhered to. Operation outside the technical specifications for the device can lead to failure and consequential damage!

**In the event of a disruption or failure of the device, functions must be monitored separately by an alarm system to prevent personal injury and/or material damage. Substitute operation must be taken into consideration! During the planning and assembly of the plant, all local regulations and laws must be adhered to.**

## 2.4 Operator's responsibilities

### 2.4.1 General

- The owner or operator must ensure that the electrical machinery and operating equipment are operated and maintained in accordance with electro-technical regulations.
- The operator undertakes to operate the device only when it is in perfect working condition.
- The device may only be used as intended in accordance with the relevant operating instructions (→ Ch. 2.1 "Use as intended").
- Safety devices must be checked regularly to ensure their perfect working order.
- The assembly instructions or operating instructions must be kept with the device in a legible condition at all times. The documents must be complete at all times.
- Personnel must undergo regular work safety and environmental protection training and must know the assembly instructions or operating instructions, especially the safety instructions contained therein.
- All safety and warning instructions on the device must not be removed and the operator must ensure that they remain legible.

### 2.4.2 Staff safety, requirements / Duty of care

Persons entrusted with the planning, installation, commissioning and service and maintenance of the device must be suitably qualified and have appropriate experience to carry out their work.

In addition, they must have knowledge of safety standards, EC directives, accident prevention regulations and corresponding national legislation as well as regional and company regulations. New personnel or personnel who are still undergoing training may only work on or with the device under the supervision of experience staff. This also applies for staff undergoing general training. The legal minimum age must be observed.

This device is not designed to be used by persons (including children) with limited physical, sensory or mental ability or those who lack experience and / or knowledge.

### 2.4.3 Personal safety equipment



**EAR PROTECTION**

For work near running fans (especially high speed motors) it is recommended that ear protection is worn for health reasons!



**SAFETY SHOES**

Safety shoes protect against heavy falling parts (especially during assembly) and against slipping on slippery surfaces.



### HAND PROTECTION

It is strongly recommended that cut resistant safety gloves are worn during assembly.

#### 2.4.4 Work carried out by external persons

Service and maintenance work are often carried out by external persons who are not always aware of special circumstances and resulting dangers. These persons must be informed in detail about dangers pertaining to their work. Their work procedures must be checked to allow timely intervention if necessary.

### 2.5 General dangers



#### DANGER FROM ELECTRICAL CURRENT!

- **WARNING!** Even after the voltage has been switched off, the following applies: as long as the motor is still running e.g. through airflow or overtravel, dangerous voltages of more than 50 V can occur at the motor connections through the generator-based operation!



#### MOVING MACHINE PARTS!

- Risk of injury from moving parts!
- During fan / motor operation, keep away from moving parts (impeller). Do not tamper with moving parts.



#### WARNING, AUTOMATIC RESTART!

- For functional reasons the fan / motor can switch on and off automatically!
- After a power cut or switching off at the mains, automatic fan restart can occur when voltage returns!
- Keep away until the fan comes to standstill!



#### WARNING, HOT SURFACES!

- Temperatures of more than 90°C can occur at motor surfaces

### 2.6 Safety instructions for phases in the product lifecycle

#### 2.6.1 Installation

For special safety and precaution measures during transport, installation, assembly and commissioning phases, please refer to the relevant chapters in these instructions!

#### 2.6.2 Operation



#### DANGER FROM ELECTRICAL CURRENT!

Identified defects in electrical machines/operating equipment must be eliminated immediately. If in the mean time there is acute danger, the device / machine must not be operated as long as it is defective.

Electrical fuses must be replaced and must not be repaired or by-passed. It is imperative that specifications for the maximum pre-fusing are observed (see Technical Data). Use only the fuses stipulated in the electrical circuit diagram.



#### ATTENTION, Danger from suction!

Do not wear loose or hanging clothing, long hair, jewellery etc.

#### 2.6.3 Maintenance and service, disassembly and waste disposal

For special safety measures for maintenance and service, as well as disassembly and waste disposal, please refer to the corresponding chapters.

### 2.7 What to do in an emergency

In an emergency, switch off fan and secure against restart!

Observe the safety instructions and warnings supplied by the plant manufacturer (complete machine → cf. Ch. 2.1.1)

### 3. Technical data

For technical data, please refer to the rating plate and the data sheet of the EC type examination certificate. The data sheet is part of the delivered documentation or can be downloaded from the website [www.suedelectric.de](http://www.suedelectric.de) (section "Download").

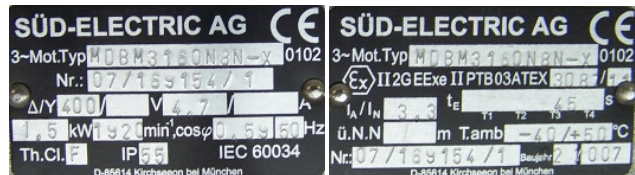

Example of Rating Plate (Süd-Electric motor + ATEX)



Example of Rating Plate Axial fan

#### General operating conditions

Fans are to be operated only within the temperature ranges stipulated on the rating plate (T.amb) and only up to the maximum pressure (Pmax). The max. permissible operating data on the rating plate apply for an air density of  $\rho = 1.2 \text{ kg/m}^3$ .

For the temperature class, please see the corresponding data sheet of the EC type examination certificate.

Voltage variation tolerance	Nominal voltage according to rating plate $\pm 5\%$
Frequency variation tolerance	50Hz or 60Hz $\pm 1\text{Hz}$
Insulation class	F
Max. permissible altitude	1000 m absolute without drop in performance
Permissible temperature range for storage and transport	-30...+80 °C
dB(A) values; weight	See product catalogue / data sheet

### 4. Construction and function

#### 4.1 Main components

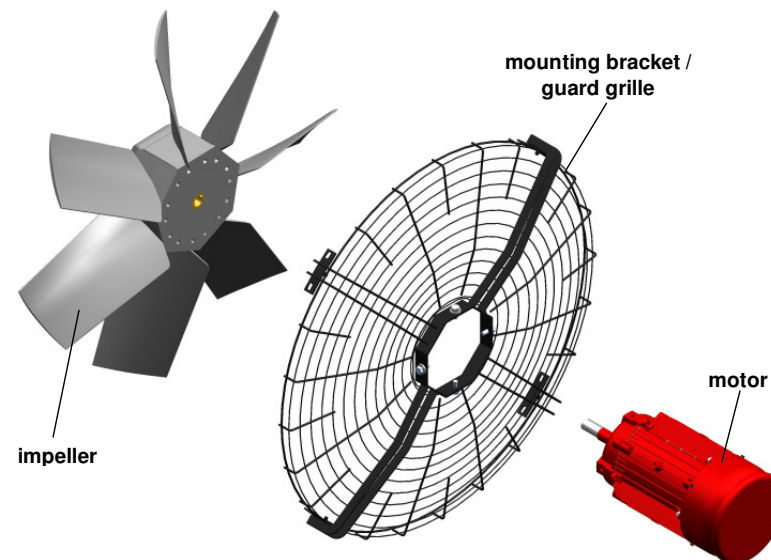

#### 4.2 Functional description

Fans are intended for the transfer of air or air-like mixtures. The air is moved by a **rotating impeller**. The impeller is screwed on to the motor shaft and is driven by the **motor**. Motor and impeller are mounted to a wall, a device (e.g. a heat exchanger) or a nozzle e.g. wall ring or pipe) by means of a **mounting bracket**, which can also act as a **contact protection**. The **nozzle** can be part of the fan unit or is integrated in a machine or device in which the fan is installed. Its purpose is to optimise the air current flow.

The fan's electrical connection takes place at the **terminal box**. If the fan is delivered without a safety grille, the manufacturer or operator of the whole machine is responsible for making sure that this poses no danger.

All motors are balanced in two planes in accordance with DIN ISO 1940, Part 1 with whole feather key.

## 5. Transport and storage

### 5.1 Safety



#### WARNING!

- Please observe information in the chapter “Safety”!
- When handling, please wear safety footwear and gloves!
- Never position yourself under the suspended fan. In the event of a defect in the hoisting device, danger to life!

### 5.2 Packaging and transport

- Süd-Electric axial fans are packaged ex works for the relevant mode of transport agreed upon
- The fan(s) must be transported either in their original packaging or in the case of larger fans on the especially prepared transport equipment (bored holes in the supporting arms, wall ring plates) with suitable means of transport
- Do not transport fan by connecting cable
- Check that there is no damage to the packaging or the fan
- Observe at all times the weight stipulations and the permissible maximum load capacity of the means of transport
- Avoid vibration and shocks during transport
- Avoid exposure to extreme heat or cold (see “Technical Data” chapter for temperature range for storage and transport)
- Secure pallets during transport
- Do not pile up pallets
- Handle with appropriate hoisting devices only

### 5.3 Storage

- Store fan / motor in its original packaging in a dry place and protected from weather conditions, protect it from dirt and weather until final assembly
- Avoid exposure to extreme heat and cold (see “Technical Data” chapter for temperature ranges for storage and transport)
- Do not pile up pallets
- Check proper functionality of motor bearing prior to installing
- Avoid excessive storage periods. We recommend a maximum of one year (in the case of longer periods, please contact manufacturer before commissioning)

Windings tend to collect humidity, especially when stored for a long time under uncontrolled conditions (humidity and temperature fluctuations). Before commissioning, therefore, the insulation must be tested with appropriate measuring devices and, if necessary, the winding must be dried.

Insulation resistance: at least 1000 Ohm/Volt (motor rated voltage)

## 6. Assembly and installation, initial operating

### 6.1 Safety



#### WARNING!

- Please observe information in the chapter “Safety”!
- Assembly, installation and commissioning by qualified personnel only!
- Incorrect installation and commissioning may lead to fatal injury!



#### DANGER TO LIFE FROM ELECTRICAL CURRENT!

- Work on electrical parts may only be carried out by qualified electrical specialists or those instructed in electrics and under the supervision of a qualified electrical specialist in accordance with technical regulations.
- The five safety rules for electricity must be observed!
- Never carry out work on live parts.
- When working on live parts or cables, a second person must always be present to switch off power in the case of an emergency.
- The fan may only be connected to an electrical circuit that can be disconnected using an all-pole isolating switch.
- The operator of the device is responsible for the EMC compatibility of the whole machine in accordance with local standards.
- Electrical equipment must be checked regularly: loose connections must be repaired; damaged lines or cables must be exchanged immediately.

### 6.2 Assembly and installation



When assembling, observe also the information in the brochure “Technical Explanations” (especially the information about installation possibilities and clearance distances). The brochure can be found at [www.suedelectric.de](http://www.suedelectric.de) in the “Download” section.

Planners, manufacturers or operators are responsible for the proper and safe assembly of the motor and the respective components (e.g. fan impeller) and for safe operation!

#### 6.2.1 General information

- It is incumbent upon the system or plant manufacturer to ensure that installation and safety instructions relevant to the machine are in keeping with the valid norms and standards (DIN EN 292/294).

- Remove the fan from its packaging using an appropriate hoisting device. Suspension points are the mounting brackets of the fan and the safety grille (depending on fan model).
- When lifting with the hoisting device the chain / rope must not come into contact with the impeller. Otherwise damage may occur.
- Check fan for possible damage before assembly, e.g. damage during transit, cracks or dents or damage to the electrical connecting cable.
- For weights greater than 25 kg for men / 10 kg for women, the removal of the fan from its packaging must be carried out by two persons (in accordance with time and motion). It is possible that values vary from country to country.
- There should be no drilling chips, screws or other foreign bodies in the device!
- Before installing fan, please check whether the safety clearance in accordance with DIN EN ISO 13857 or in household devices in accordance with DIN EN 60335 is adhered to. If a fan is within a danger zone, the manufacturer of the aggregate plant or the operator must ensure that risks are eliminated by using a protective construction (safety grille) in accordance with DIN EN ISO 13857.
- Any constructions made by the customer must correspond with the level of strain placed upon them. Apply stipulated torque for securing fixing materials.
- For usage in ambient temperatures under -10 °C all unusual, sudden or mechanical stress or strain on the material must be avoided (for min. permissible ambient temperature, see "Technical Data" or "Safety" chapter).
- Stainless steel components: nozzles, grilles, air ducts made of rustproof stainless steel 1.4301 (V2A) can become magnetic through knocks and shocks (cold distortion!). This must be avoided because in the case of plastic/stainless steel material pairing, the steel must be austenitic and not magnetic (DIN EN 14986).
- When commissioning / setting up, the ambient temperature, humidity, ambient atmospheric pollution and corrosion from ambient atmosphere must be taken into consideration.

### 6.2.2 Mechanical installation

The following applies for **all** models of axial fans:

- Enough space must be available! Mounting surfaces must be even
- Distortions and movements must not lead to moving parts rubbing
- Do not use force (levering, bending)
- Make sure impeller wheel can move freely without rubbing
- According to DIN EN 14986, the distance between blade and nozzle must be at least 1% of the nozzle diameter (no smaller than 2 mm!)
- Ensure there is an even gap between fan blade and mounting plate
- Fixing at all mounting points with appropriate mounting fixtures
- In the case of a vertical motor shaft (IP 44), the underlying condensation water drains must be open

The following clamping torque for screws should be observed for the assembly of motors and fans:

Junction plates	4 Nm				
PTC thermistor clips Bartec	0,4 Nm				
Terminal box	M4	M5	M6		
	3 Nm	3,5 Nm	4,5 Nm		
Blade mounting	M5	M6	M8		
	(A2 screws, strength grade 80)	6 Nm	8 Nm	22 Nm	
Grille and fan mounting	M5	M6	M8	M10	M12
	(A2 screws, strength grade 80)	6 Nm	8 Nm	22 Nm	43 Nm 75 Nm

### 6.2.3 Explosion group IIC



**Consider for application explosion group „IIC, only hydrogen“ the following:**

**The ex-motor and the safety grille must be mounted electrically conductive at the mounting plate, the nozzle or the air duct. The contact points must be protected reliably against corrosion. When fixing the fan to the customer equipment take care of electrically conductive connection between safety grille and mounting plate / customer equipment. Painting or coating of parts that are passed through by air (nozzle, air duct, pipe): Due to possible electrostatic charge the coat thickness must not exceed 0.2 mm.**

#### Version with zinc spray

One fixing point safety grille / motor and one fixing point safety grille / nozzle is designed with conductive zinc spray.

#### Version with contact disc

Use included contact discs for mounting the safety grille. The contact discs interrupt the coating of the safety grille. Protect contact points against corrosion (moisture protection spray). We recommend the renewal of corrosion protection: Once a year during maintenance works.

### 6.2.4 Cable gland

The connecting cable is led through the cable gland into the terminal box. All openings in the terminal box must be sealed with especially certified cable- and line lead-ins as well as sealing plugs in accordance with Guideline 94/9/EC.

- Design M20 x 1.5 Ex e
- Temperature range -40°C to +70°C
- Protection class IP66
- For fixed cable laying, small degree of mechanical risk
- Clamping range: round cable, 8 to 13 mm diameter
- Torques: screw-in thread in housing: 3.75 Nm; pressure screw with min. cable diameter 3 Nm; pressure screw with max. cable diameter 2.5 Nm

### 6.2.5 Electrical Connection

- Electrical connection according to connection diagram in the terminal box (glued in), connection diagram must be available at operating location

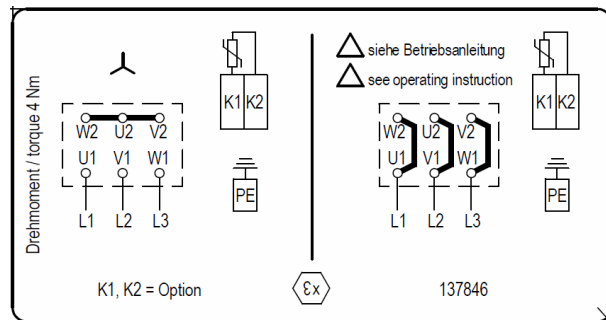

**Example of connection diagram**

- Motor connection cable: the cross-section must be determined according to recognised technical rules bearing in mind the specifications in the EC type examination certificate. A possibly reduced current-carrying-capacity due to the ambient temperature or cabling conditions is to be observed. The max. permissible terminal cross-section is 2.5 mm<sup>2</sup> for motor series 1 and 2 (MDA-1...- MDA-20...-) and 4 mm<sup>2</sup> for motor series 3 (MD-3...-)
- Connect only one wire to each motor terminal
- Protective conductors and external earth wires (potential equalisation) must be connected. The cross-section range of the intended PE clamps is 1.5 to 4 mm<sup>2</sup>
- All conducting mounted and accessory parts must be earthed
- Fix fan connection cables with cable clips to safety grilles or motor mounting parts
- If the installed temperature limiter is activated, an all-pole disconnection must be ensured using an all-pole cut-off device. The contact must be broken at each pole with a minimum distance of 3 mm



**If the fans are completed with components from other manufacturers, the manufacturer or operator of the aggregate machine is responsible for observing the EMC guideline 89/336/EWC and for adhering to the clearance distance between blade and nozzle according to DIN EN 14986!**

**In the case of a motor from an external supplier (not Süd-Electric) the documentation of the manufacturer is enclosed. Take note of this documentation! It must be forwarded to the subsequent owners.**

### 6.3 Initial operation



**WARNING!**

**During commissioning unexpected and dangerous circumstances can occur in the aggregate machine because of incorrect settings, faulty components or wrong electrical connection!**

Prior to initial operation, please check:

- Mounting and electrical installation carried out correctly; protective conductors and external earth wires (potential equalisation) are connected
- Safety equipment mounted (contact protection)
- Assembly residues and foreign bodies removed from fan
- Temperature limiter (protector) / motor circuit breaker properly connected by trained staff and functioning
- Cable entry sealed (see "Assembly")
- Does the installation match the positioning of the condensation drain holes (IP 44)
- Do the connection data match the data on the rating plate
- Rotating parts, e.g. impeller, must not rub against stationary parts (clearance distance in accordance with DIN EN 14986)

Commissioning can occur only when all safety instructions have been checked and all dangers eliminated.

- Check direction of rotation / direction of airflow
- Check for smooth running:  
Strong vibrations from imbalance e.g. due to damage in transit or unprofessional handling can lead to failure
- Natural resonance:  
The motor speed which causes increased vibrations due to natural resonance depends on the aggregate machine. Natural resonance testing must be carried out by the machine builder when designing the device or during commissioning.

## 7. Operation and maintenance

### 7.1 Safety



#### WARNING!

- Danger of injury through improper use!
- Before switching on device, make sure that all covers and protective equipment are installed and function properly!
- When operating the fan, the maximum permissible speed must not be exceeded!

### 7.2 Operating conditions

☞ See also chapter 2 “Safety” and chapter 3 “Technical Data”

#### The use of a frequency inverter is not permissible!

- The motor must only be operated with the rated voltage shown on the rating plate. The rated voltage according to zone A of the Norm EN 60034-1 may continuously deviate from the rated value by up to 5%.
- The use of an appropriate motor circuit breaker is mandatory. Take into consideration the standard EN 60079-14 and the specifications on the rating plate of the motors. The electrical thermally delayed monitoring device must be approved according to RL 94/9/EC and have at least the designation  II (2) G.
- If the fan-motor unit is mounted to an external source of heat/cold, the following applies: the temperature must be within the permissible ambient temperature range.

### 7.3 Instructions for use of PTC thermistors

As an alternative to using electrical motor protection devices or motor circuit breakers (thermally delayed over-current relays) Süd-Electric motors can be equipped with triplet PTCs in accordance with DIN 44082-M. The use of PTC thermistors as an alternative protection device to electrical motor monitoring devices is only permissible when stipulated on the data sheet of the EC type examination certificate.

Temperature recording with PTCs is wise in the case of fans which are operated at their capacity limit and for temperatures less than +10°C. The air density is higher in cold air and therefore the motor current can be higher than the rated current. PTCs or tripping unit protect the motor and guarantee the required operating safety. The tripping unit must be certified in accordance with Guideline 94/9/EC, bear the corresponding designations [ II (2) G] and disconnect the motor from the mains and secure against restart. The tripping unit is not included with delivery.

When operating Süd-Electric motors with PTC thermistors, observe the following points:

- The maximum testing voltage of the PTC thermistor is 2.5 V
- More than two PTC thermistor chains must not be switched in series because this can lead to undefined shut-down

### 7.4 Outdoor installation

When idle for a longer period of time in a humid atmosphere it is recommended that fans be operated for at least 2 hours each month to allow any moisture to evaporate.

### 7.5 Maintenance and service



#### WARNING!

- Please observe information in the chapter “Safety”!
- When carrying out repair and maintenance work, please observe standard operation and safety procedures in accordance with DIN EN 50110, IEC 364, DIN EN VDE 0105, BGV A2!
- Repairs may only be carried out by qualified specialists!
- The motor must be disconnected from the mains power supply and secured against re-start!
- No maintenance work on fans which are running!
- Keep all airways free – danger from expelled objects!
- The machine builder must enable easy access for cleaning and inspection work!

- Regular inspection of any deposits necessary and, if necessary, the cleaning thereof (see below) in order to prevent imbalance caused by dirt particles. Imbalance can lead to damage (danger of fatigue breakage). The impeller can burst!
- Service intervals depend on degree of soiling on fan wheel.
- If there is a danger of caking or ice build-up, the fan must be checked at regular intervals.
- Ensure smooth running. In the case of imbalance: re-balance impeller.
- Check impeller for possible cracks.
- In the case of 1~motors, the capacitor capacity can deteriorate with time. Life expectancy 30,000 hours in accordance with DIN EN 60252.
- Check for unusual noises during operation!
- Due to the use of bearings with “lifetime lubrication“, the axial fan is service-free. At the end of the grease service life (for standard usage 30 – 40,000 h), the bearings must be changed.
- Change bearings at the end of the grease service lifetime or in the event of damage in factory only (special tools needed!). Please contact our service department.
- Check fan and cable for damage and have changed if necessary by professionally trained staff.
- For all other types of damage (e.g. damage to windings), please contact our service department.

7.6 **Cleaning**



**DANGER FROM ELECTRICAL CURRENT!**

- The motor must be **disconnected from the mains and secured against re-start!**
- Wet cleaning when connected to mains can give you an electric shock – **DANGER TO LIFE!**



**WARNING!**

- No aggressive, paint-dissolving detergents may be used for cleaning
- Please note that no water should enter the inside of the motor, observe protection class (IP)
- Never use high-pressure cleaner
- After cleaning, the fan must be operated at rated speed for 30 minutes in order to dry!

8. **Fault diagnostics**

8.1 **Safety**



**WARNING!**

- Danger of injury from improper repair work!
- Improper repair work can lead to serious personal injury and/or material damage!
- Please observe safety instructions in the chapters “Safety” and “Assembly and Installation, Initial Operation” at all times!

8.2 **What to do in the case of failure and disruptions**

The following general rules apply:

1. In the case of failures which may constitute a danger for persons or material, operate emergency stop switch
2. Investigate cause of failure
3. Inform person responsible at the site of operation
4. If necessary, contact manufacturer: service address ☞ “Important Basic Information”

8.3 **Fault diagnostics and elimination**

Type of error	Possible cause(s)	Action
Fan does not turn (no longer turns)	No voltage from mains	Check mains power supply
	Phase outage	
	Under- or overvoltage	Check cable and motor insulation
	Short to ground	
	Short between windings	
Thermal motor protection is activated (motor is overloaded)	Check for free airways; if necessary remove foreign bodies ☞ “impeller blocked or dirty” Check temperature of supply air Check voltage	
Impeller is blocked or dirty	- Switch off motor and secure against re-start - Check that motor is set to zero-potential - Remove safety grille - Remove foreign bodies or dirt particles	

Type of error	Possible cause(s)	Action
		- Put back safety grille - Next steps as in chapter "Initial Operation"
Fan does not start	Temperature too low for bearing grease	Use bearings with special lubrication suitable for cold temperatures
	Airflow in wrong direction (Motor turns the wrong way round at high speed)	Check airflow
	☞ "fan does not turn"	
Fans turns too slowly	Impeller/Blade cannot move freely	- Turn off fan immediately - If necessary, remove foreign body/dirt from the fan
	Capacity of operating capacitor (only for 1~motor)	Check capacitor, change if necessary
Airflow rate too low	☞ "Fan turns too slowly"	
	Airways blocked	Check that airways are free (ingoing/outgoing air flaps, filters) ☞ "impeller is blocked or dirty"
	Loss of pressure differs from that which was projected	Check choice of fan
Vibrations	Imbalance	Check blades for damage, dirt particles or icing ☞ "Impeller is blocked or dirty"
Unusual noises	Bearing faulty/worn	Change bearing
	Impeller/blade rubs	If necessary remove foreign bodies/dirt from the fan ☞ "Impeller is blocked or dirty"
	Operation beyond stall point (in the case of axial fans)	Check for free airways (incoming / outgoing air flaps, filters)

## 9. Disassembly and waste disposal

### 9.1 Safety



#### WARNING!

- Please observe instructions in chapter "Safety"!
- Disassembly only by qualified specialists!
- When handling, use safety footwear and gloves!

### 9.2 Disassembly

The following general rules apply:

- Switch off motor voltage supply and secure against re-start
- Check that motor is set to zero-potential
- Remove safety grilles and fan
- Handle with appropriate hoisting devices
- Observe weight stipulations at all times and the permissible bearing load of the relevant means of transport
- On no account stand underneath the suspended fan. A defect in the hoisting device may lead to severe injury or death

### 9.3 Waste disposal / Recycling

Fans must be disposed of properly and in an environmentally friendly manner in accordance with legal requirements.

10. Declaration of incorporation

**Einbauerklärung / EG-Konformitätserklärung - Original**  
*Declaration of incorporation / EC Declaration of Conformity - Translation*

im Sinne der EG-Richtlinie Maschinen 2006/42/EG, Anhang II B, der EMV-Richtlinie 2004/108/EG und der ATEX-Produktlinie 94/9/EG

as defined by the EC Machinery Directive 2006/42/EEC, Annex II B, the EMC Directive 2004/108/EEC and ATEX-Product Directive 94/9/EC

Die Bauart der Maschinen – Gas Atmosphäre  
*The type of machinery – Atmosphere G (Gas)*

**Drehstrommotoren für explosionsgefährdete Bereiche**  
**Zündschutzart Erhöhte Sicherheit „e“ II 2 G Ex e II T1, T2, T3 oder T4**  
*Three-phase motor for explosion-hazardous areas*  
*Type of protection Increased safety „e“ II 2 G Ex e II T1, T2, T3 or T4*

**MD.-. mit EG-Baumusterprüfbescheinigung PTB 03 ATEX 3080, PTB 03 ATEX 3081 und PTB 03 ATEX 3087**  
*MD.-. with EC-type examination certificate PTB 03 ATEX 3080, PTB 03 ATEX 3081 and PTB 03 ATEX 3087*

**Axialventilatoren L.- der Gruppe II, Gerätekategorie 2G für die Förderung von explosionsfähiger Atmosphäre der Zone 1 und Zone 2 der Explosionsgruppe IIB sowie IIC nur Wasserstoff mit Innenläufermotor MD.-. für explosionsgefährdete Bereiche, Zündschutzart Erhöhte Sicherheit „e“**  
*axial fans L.- Group II, 2G appliance category for the conveyance of potentially explosive atmosphere from zone 1 and zone 2 of explosion group IIB as well as IIC only hydrogen with internal rotor motor MD.-. for explosion-hazardous areas, "e" type of protection respectively protection*

Motorbauart  
*Motor type*

**Drehstrom-Innenläufermotoren**  
*Three-phase A.C.-internal rotor motor*

ist entwickelt, konstruiert und gefertigt in Übereinstimmung mit den EG-Richtlinien 2004/108/EG, 94/9/EG und 2006/42/EG, in alleiniger Verantwortung von  
*is developed, designed and manufactured in accordance with the EC Machinery Directive 2004/108/EEC, 94/9/EC, 2006/42/EC, on the own responsibility of*

Hersteller **SÜD-ELECTRIC AG**  
*Manufacturer* **Westring 1-7**  
**D-85614 Kirchseeon bei München**

Folgende EG-Richtlinien und harmonisierte Normen sind angewandt:  
*The following EC Directives and harmonized standards are in use:*

**93/68/EWG, 94/9/EG**

**EN ISO 13857:2008, EN 60034-1:2004, EN 60204-1:2006, EN 61000-6-2:2006, EN 61000-6-3:2007,**

**EN 60079-0:2006, EN 60079-7:2007, EN 1127-1:1997, EN 13463-1, EN 13463-5:2003, EN 14986:2007**

Name, Anschrift und Kennnummer der benannten Stelle, die für die Überwachung der elektrischen, explosionsgeschützten Betriebsmittel der Gerätegruppe II, Kategorie 2 zuständig ist:  
*Name, address and designation no. Of the technical institute:*

**Physikalisch-technische Bundesanstalt (PTB)**  
**Bundesallee 100, 38116 Braunschweig, Kennnummer 0102**

Hinweise:  
*Remarks:*

- Die Einhaltung der EN ISO 13857 bezieht sich nur auf den montierten Berührungsschutz, sofern dieser zum Lieferumfang gehört. Für die vollständige Erfüllung der EN ISO 13857 ist der Anlagenbauer verantwortlich.  
*Conformity with EN ISO 13857 only refers to the fitted contact safety device, provided that it is part of the extent of delivery. The system manufacturer is responsible for the complete compliance with EN ISO 13857.*
- Die Einhaltung der EG-Richtlinie EMV 2004/108/EG bezieht sich nur dann auf dieses Produkt, wenn es nach Betriebsanleitung (Schaltplan) angeschlossen ist. Wird dieses Produkt in eine Anlage integriert oder mit anderen Komponenten (z.B. Regel- und Steuergeräte) komplettiert und betrieben, so ist der Hersteller oder Betreiber der Gesamtanlage für die Einhaltung der EG-Richtlinie EMV 2004/108/EG verantwortlich.  
*Conformity with EMC Directive 2004/108/EC only applies to this product if connected in compliance with the operating instructions (circuit diagram). If the product is integrated in a system or combined with other components (e.g. controllers), the system manufacturer is responsible for compliance with EC Directive EMC 2004/108/EC for the complete system.*
- Die Einhaltung der Norm DIN EN 14986 bezieht sich nur dann auf das montierte Drahttragegitter und die Einströmdüse, wenn diese zum Lieferumfang gehören. Für die vollständige Erfüllung der Norm DIN EN 14986 sowie für die Einhaltung der Werkstoffpaarungen und der Mindestspalte ist der Anlagenbauer verantwortlich.  
*Conformity with the standard DIN EN 14986 refers only to the installed wire screen and the inlet nozzle if these belong to the scope of supply. The manufacturer of the plant is responsible for the complete compliance with the standard DIN EN 14986 as well as for the combinations of material and the minimum gap.*

Eine technische Dokumentation ist vollständig vorhanden.  
*Complete technical documentation is available.*

Bevollmächtigte Person für das Zusammenstellen der CE-Dokumentation ist: Leitung Technik. Anschrift s. Seite 1  
*The person authorised to compile the CE- documentation is: Head of Technical Engineering, see page 1 for address*

**Die Inbetriebnahme dieser Maschine ist solange untersagt, bis sichergestellt ist, dass die Maschine, in die sie eingebaut wurde, den Bestimmungen der EG-Richtlinie Maschinen 2006/42/EG Sicherheit von Maschinen entspricht.**  
*This machinery must not put into operation until the machinery into with it is incorporated has been declared to conform with the EC Machinery Directive 2006/42/EEC.*

Kirchseeon, den 10.12.2010

Ort, Datum



Josef Freinberger  
Leitung Technik Süd-Electric AG